

H8PU Low Voltage

MOTOR CONTROL CENTER



H8PU LOW VOLT

■ ■ ■ *H8PU Low Voltage*

Motor
Control
Center



H8PU Low Voltage

MOTOR





CONTROL CENTER



HYUNDAI's low voltage motor control center H8PU series with a withdrawable unit are of multi-tier, factory assembled and for rated voltage of up to 660V AC.

Contents

MCC

| | |
|----------------------------|----|
| Design Concepts | 4 |
| Applicable Standards | 5 |
| Protection Degrees | 5 |
| Service Conditions | 6 |
| Enclosures | 6 |
| Finish | 7 |
| Name Plate | 7 |
| Routine Tests | 7 |
| H8PU-S2 / S3 | 8 |
| H8PU-S7 | 16 |

HCB

| | |
|---|----|
| Characteristics of HCB Series | 23 |
| Technical Data | 24 |
| Protective Characteristics | 25 |
| Setting Standards and Adjustable Ranges | 26 |
| LCD Display Contents/Order Form | 27 |
| Setting Key Operation | 28 |
| Setting Method | 29 |
| Outline Dimensions and Connection Diagram | 30 |
| Plug-in Mounting Base Structure and Outline | 31 |

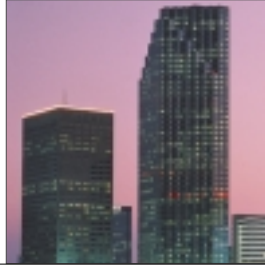

H8PU motor control center have been designed and manufactured in accordance with our quality assurance program.

Design Concepts

All withdrawable units are designed to satisfy MCC requirements.

Main switches (fused load-breaks switch or moulded case breakers) are provided in every starter.

The switch drive is interlocked with compartment doors or covers.
(The door can only be opened with the main switch in the OFF position)

Padlock can be attached to the handle of main switches in the ON and OFF positions.

Maximum safety and reliability.

Minimum maintenance, all parts easily accessible.

Ease of installation.

Simplified but flexible design.

Compatibility with any other types of switchboard.

The motor control center type H8PU-S2 is of plug-in arrangement for both line, load and control circuit of isolating contact.

The motor control center type H8PU-S3 has three positions in the draw out unit:
DISCONNECTED, TEST and CONNECTED POSITION.

The limit switch assembly mounted on the draw out mechanism works in the test and connected position. (option)

The motor control center type H8PU-S7 applies to HCB as new concept. HCB is composed compactly of many motor starter functions as integral part: MCCB, MC, EOCR, CT, AM, ZCT (option), ELR (option).
[for further information: refer to HCB catalogue]

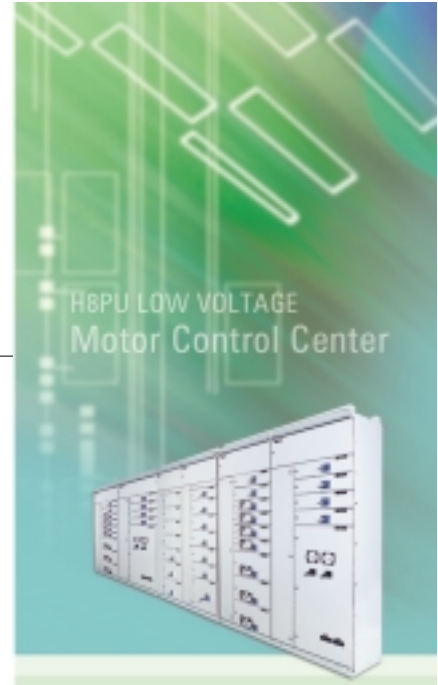

H8PU LOW VOLTAGE
Motor Control Center

*Design Concepts
Applicable Standards
Protection Degrees*

Applicable Standards

H8PU motor control center comply with the following international standards.

- IEC 439-1
- VDE 0110
- BS 5486

Protection Degrees

The protection degrees for standard switchgear are as follows.

- Protection degree for the switchgear enclosure: IP4X
- Protection degree for the internal partition: IP2x

The other degrees such as IP41, IP51 are also available on request.

Description of Protection Degree

| Degree | Description of Protection |
|--------|---|
| IP2X | Protection against access to hazardous parts with finger or solid foreign objects of diameter greater than 12mm. No specification against water. |
| IP4X | Protection against access to hazardous parts with wires of diameter or strips of thickness greater than 1.0mm. No specification against water. |
| IP41 | Same as IP4X, but vertically falling drops protection is added. |
| IP51 | Same as IP41, but dust protection is added. (Ingress of dust is not totally prevented, but dust shall not penetrate in a quantity to interfere with satisfactory operation) |



Service Conditions
Enclosures
Name Plate
Finish
Routine Tests

Service Conditions

HHI's switchgears are intended for use under the normal indoor service condition and special service condition.

Normal indoor service condition

Ambient temperature: 35°... maximum 24hours mean.
40°... maximum value.

Altitude not to exceed 1000M sea level.

Relative humidity: 95% maximum 24hours average.
90% maximum one month average.

Special service condition

Following conditions are considered as special service condition.

Different value other than specified in indoor service conditions.

Outdoor service.

Heavy vibration or shocks.

Hazardous area.

Seismic requirements for nuclear power plant.

Enclosures

The rigid enclosures of the switchgear consist of steel sheets with folded edges bolted together.

The use of CNC machine and FMS (Flexible Manufacturing System) enable high accuracy of dimension, thus facilitating best quality and installation saving at site.



Finish

The enclosure of the switchgear is cleaned, rust proofed and painted in accordance with Hyundai's standard electrostatic powder coating procedure.

The average thickness of painted finish is 50 microns.

Standard finish colours are Munsell no. 5Y 7/1 and RAL7032. (Both are coloured light gray)

The equipment frame for withdrawable unit and internal barrier are made of sheet coated with anti-corrosive Al+Zn. This ensures a firm earth connection.

Name Plate

Material : Laminated plastic (White background or black background)

Fixing method : PVC lock (Sealer)

Routine Tests

The routine test are conducted with each unit at HHI's factory to ensure that the switchgears are in accordance with the requirements.

Verification of construction.

Electrical operation test.

Withstand voltage test.

H8PU LOW VOLTAGE
Motor Control Center
>> **H8PU-S2/S3**



Construction
Comparison Table

H8PU-S2/S3



Front view of M.C.C type H8PU-S2



Front view of M.C.C type H8PU-S3

Construction

The modular designed, standard motor control center type H8PU-S2, S3 consists of a bolted frame work with the associated compartment doors and covers.

M.C.C type H8PU-S2 cubicle is segregated by partition sheets into functional compartment; **busbar compartment, module & cable compartment.**

M.C.C type H8PU-S3 cubicle is segregated by partition sheets into functional compartment; **busbar compartment, module compartment and cable compartment.**

The cubicles can be chosen as " front only (one side operating) " cubicle or as " back to back (both side operating)" cubicle.

The main busbars are installed horizontally in the upper or lower sub-section of the cubicle.

The vertical busbar system is designed for a 3pole or 4pole plug in system.

Motor control center type H8PU-S2, S3 maybe provided with a central control and indication system via control circuit busbars.

The module space of each cubicle is separated for max. 24 modules.
(24° × 80 mm)

The module compartment 2,3,4,5,.10, as well as the cable compartment have their own separate door.

The compartments for the modules can be easily rearranged by qualified personnel without danger and switching off the switchboard.

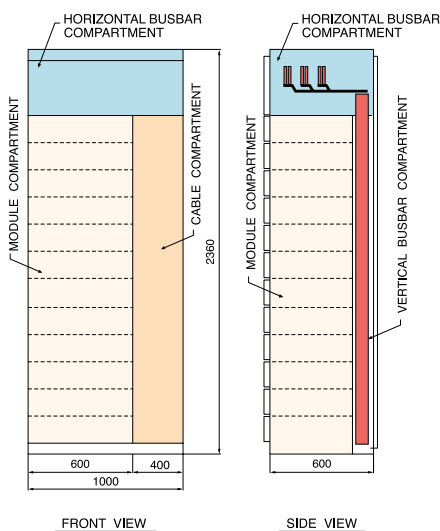

Motor control center
type H8PU-S3



Comparison Table

| Description | H8PU-S2 | H8PU-S3 | Remark |
|---|----------------------------|------------------|-------------------------------------|
| Form of separation (IEC 439-1) | Form 2 Form 3b (option) | Form 3b/4 | |
| Moving of the isolating contact for line side | N/A | Screw drive type | |
| Limit switch of position | N/A | 2 position | Test position Connected position |
| Isolating contact for load side | Auto | Auto | |
| Isolating contact for load side | Auto | Auto | |
| Isolating contact for control circuit | Manual Auto (option) | Auto | |

Form of internal separation

In accordance with IEC 60439-1, depending on requirements, the function compartments can be subdivided as per the following table.

| | Form | | | | | | |
|--------------------------------|------|----|----|----|----|----|----|
| | 1 | 2a | 2b | 3a | 3b | 4a | 4b |
| Circuit-breaker design | ■ | ■ | ■ | ■ | ■ | ■ | ■ |
| With-drawable unit design | | | | | ■ | | ■ |
| Plug-in design HCB(S7-Series) | | | ■ | | ■ | | |
| Fixed-mounted design - Modular | | | ■ | | | ■ | |

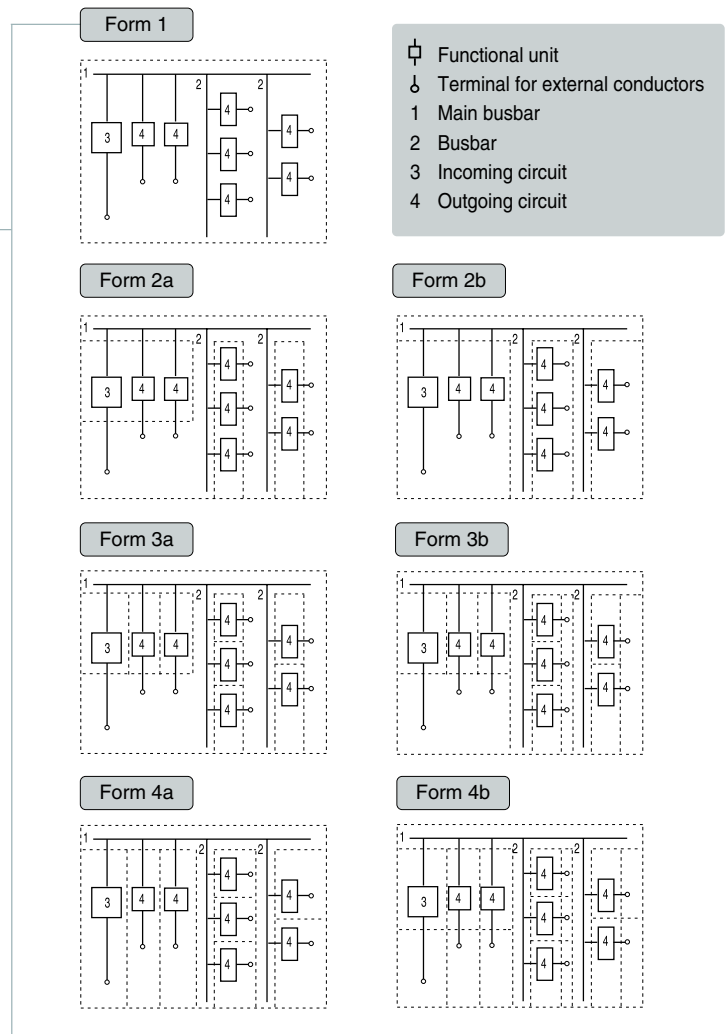

Forms of internal separation to IEC 60439-1



Busbar Compartments

Horizontal busbars

The main busbars, which are made of copper, are installed horizontally in the upper or lower sub-section of the cubicle.

Each phase consists of two rectangular-section conductors mounted side by side and on edge. In all the section, the busbars run in the same front section.

This makes it possible for the busbars to be kept equidistant and well aligned.

The busbars have been supported with high quality insulating material, in the form of arc barriers, so that it prevents an arc from spreading out into the adjacent compartments.

Vertical busbars

Power is fed to the withdrawable units through the isolating contacts of the main switch, which plug on to the vertical busbars.

The vertical bar is rated 650A or 850A depending on the requirement.

They are housed in an U-shaped duct and are supported by bus holders that provide a peak fault current rating of $I_s = 143\text{kA}$.

Vertical bar section: $60 \times 6\text{ mm}$,
 $60 \times 8\text{ mm}$

Arrangement of horizontal busbars and control circuit busbars

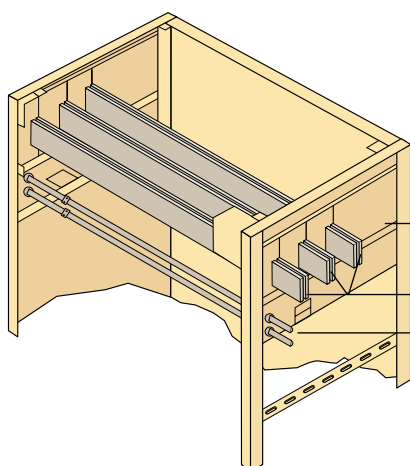

1. Busbar supports (polyester with glass)
2. Horizontal busbars
3. Control circuit busbars

Protection against touching

When the unit is withdrawn, a shutter covers the vertical bars to prevent inadvertent contact with the live bars.



Busbar Compartments

Technical data at a glance

| | | |
|---|-------|-----------------------------|
| Rated insulation voltage (U _i) | | 1000 V |
| Rated operational voltage (U _e) | up to | 690 V |
| Busbar currents (3-and 4-pole) | | |
| Horizontal main busbars | | |
| Rated current | up to | 5000 A |
| Rated impulse withstand current (I _{pk}) | up to | 250 kA |
| Rated short-time withstand current (I _{cw}) | up to | 100 kA |
| Vertical busbars | | |
| for circuit-breakers design | | |
| See horizontal main busbars | | |
| for fixed-mounted design / plug-in design | | |
| Rated current | up to | 2000 A |
| Rated impulse withstand current (I _{pk}) | up to | 110 kA |
| Rated short-time withstand current (I _{cw}) | up to | 50 kA ¹⁾ |
| for withdrawable-unit design | | |
| Rated current | up to | 1000 A |
| Rated impulse withstand current (I _{pk}) | up to | 143 kA |
| Rated short-time withstand current (I _{cw}) | up to | 65 kA ¹⁾ |
| Device rated | | |
| Circuit-breakers | up to | 5000 A |
| Cable feeders | up to | 1600 A |
| Motor feeders | up to | 630 A |
| Power loss per cubicle with combination of various cubicles (P _V) | | |
| | | approx. 600 W ²⁾ |
| Degree of protection to IEC 60529 | | IP 20 up to IP 54 |

¹⁾ Rated conditional short-circuit current I_{cc} up to 100 kA
²⁾ Mean value at simultaneity factor of all feeders of 0.6

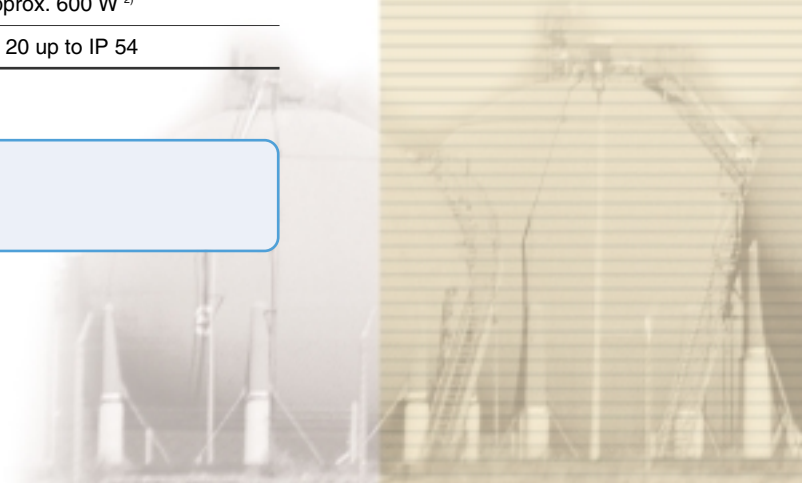

H8PU LOW VOLTAGE
Motor Control Center

>> **H8PU-S2/S3**



Module Compartments

Module Compartments

Withdrawable units

Each withdrawable unit housed in its own self contained compartment. The height of the board within which compartments can accommodate is 1920mm.

This is divided into 24 modules. (1 module = 80mm high)

The smallest withdrawable unit is 2 modules (160mm high) and the largest one is 10 modules (800mm high)

The compartment comprises of the door, the support panel with the unit guides and isolating contacts for main and control circuits together with the withdrawable unit from a "functional unit".

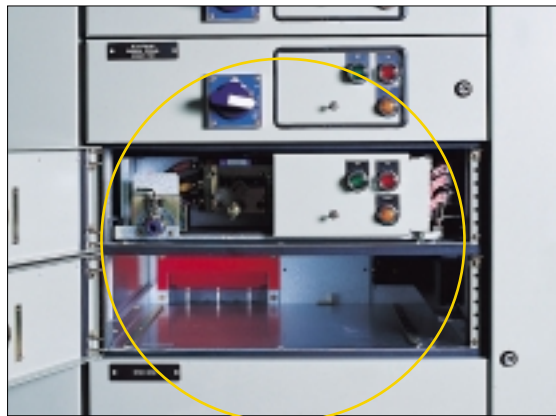

Withdrawable unit of motor control type H8PU-S3

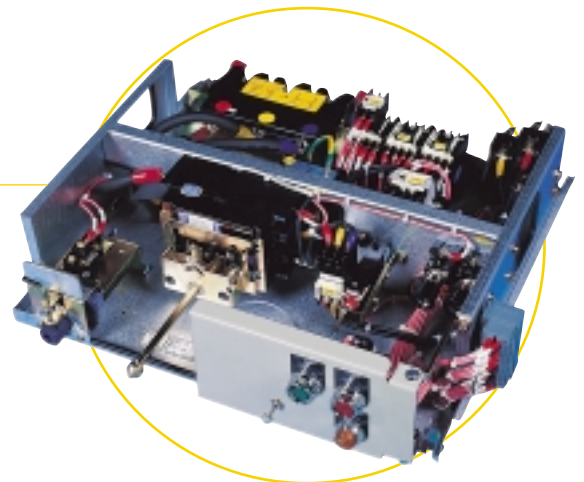



Moving of the Isolating Contact Systems

(M.C.C type H8FU-S3 only)

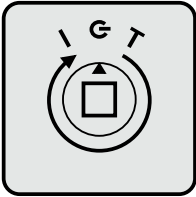
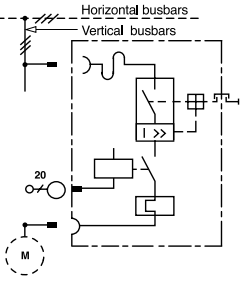
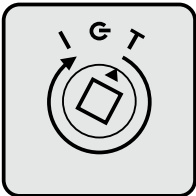
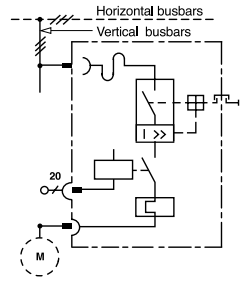
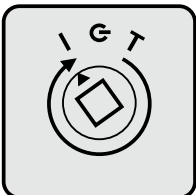
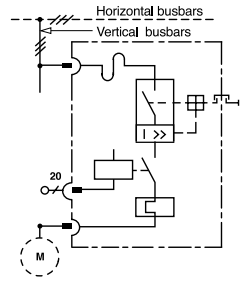
| Designation of position | Position indication | Withdrawable principle | Description of function |
|------------------------------|---|---|---|
| Disconnected position |  |  | Isolating contact system for line side: open for load side: open for cont. circuit: open |
| Test position |  |  | Isolating contact system for line side: open for load side: closed for cont. circuit: closed |
| Connected position |  |  | Isolating contact system for line side: closed for load side: closed for cont. circuit: closed |

The limit switch assembly mounted on the drawout mechanism works in the connected and test position. (option)

H8PU LOW VOLTAGE
Motor Control Center

> **H8PU-S2/S3**



Cable Compartments

Cable Compartments

Cable termination

Following standard versions are available.

Front only / Front cabling access type

A separate cable compartment door is provided on the right side of panels.

Back-to-back type

A separate cable compartment door is provided on each right side of panels.

Front only / Rear cabling access type

A separate cable compartment is provided at the rear of the panels and is completely isolated from the module compartment.

Control supply

For control supply derived from a common transformer, facilities are provided for the accommodation of up to 5 horizontal and up to 6 vertical control supply busbars. Horizontal control supply bars are housed in a free space below the busbars chamber.

The control supply is fed to the individual withdrawable unit with up to 3 sets of vertical double pole control busbars.

They are fitted to the right-hand side of the vertical bar duct and are connected to contacts in the 24- pole control circuit isolating plug.



Cable compartment
of motor control
center type H8PU-S3



Panel arrangement and dimensions

• Bottom cable entry (standard type)

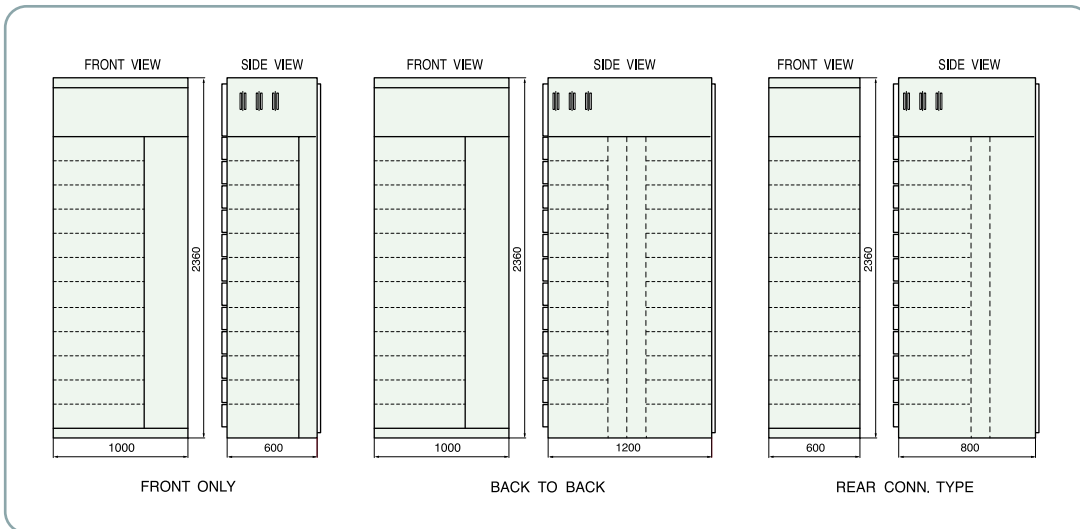

• Top cable entry (option)

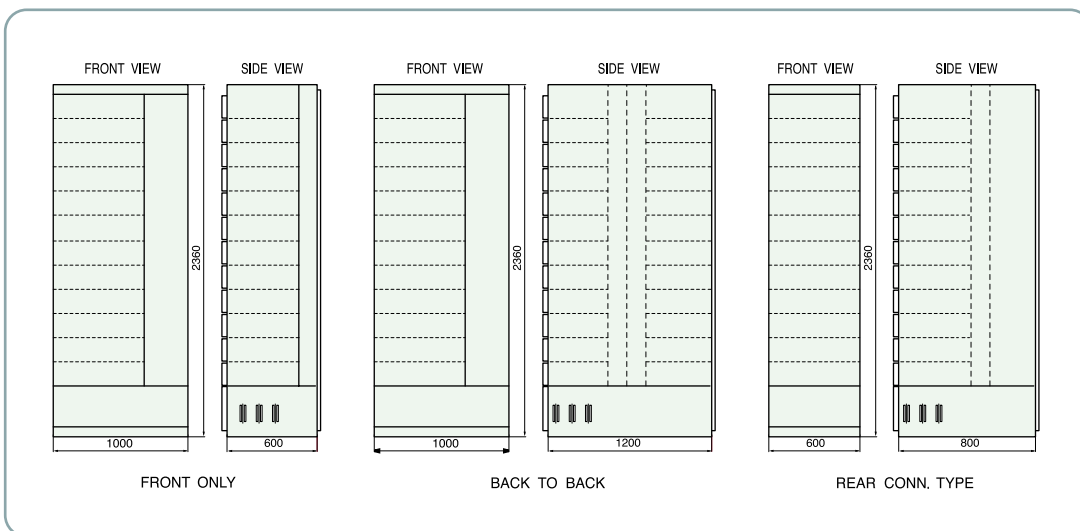

The height with bottom base frame is 2400mm (special type)

| Standing against a wide panel | Standing against a wall wide panel | Standing against a narrow panel |
|---|---|--|
| Front mounting | Back-to-back mounting | Front mounting |
| Front cabling access | Front and rear cabling access | Rear cabling access |
| Separate cable compartment door at side | Separate cable compartment door at side | No separate cable compartment door at side |

H8PU-S7

The motor control center type H8PU-S7 applies to HCB as new concept. HCB is composed compactly of many motor starter functions as integral part ; MCCB, MC, EOCR, CT, AM, ZCT (option), ELR (option).
(for further information: refer to HCB catalogue)

Construction

The motor control center type H8PU-S7 consists of a bolted frame work with the associated compartment doors and covers.

The cubicle is segregated by partition sheets into functional compartments **busbar compartment, module compartment and cable compartment.**

The cubicles can be chosen as " front only (one side operating)" cubicle or back to back (both side operating)" cubicle.

The motor control center H8PU-S7 can be combined with other H8PU series including horizontal busbars and cubicle.

The main busbars are installed horizontally in the upper or lower sub-section of the cubicle.
The vertical and branch busbar system is designed for a 3pole plug in system.
The module compartment as well as the cable compartment have their own separate door.

Construction
Busbars Compartments
Module Compartments



Inner view of motor control center type H8PU-S7

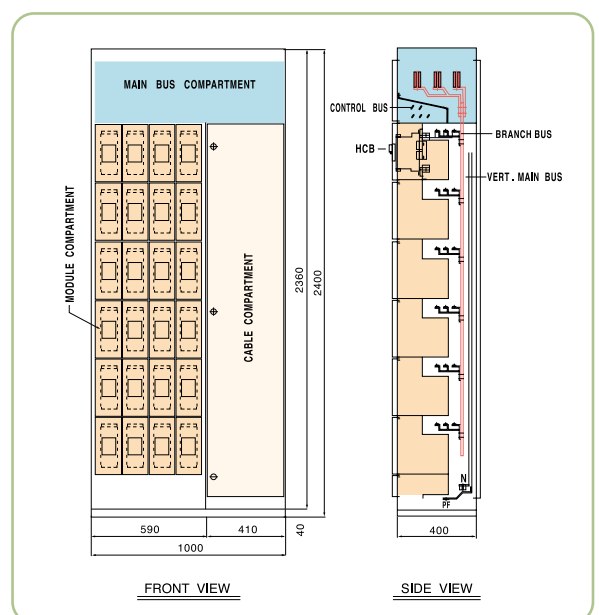



Busbars Compartments

Horizontal busbars

The main busbars, which are made of copper, are installed horizontally in the upper or lower sub-section of the cubicle.

Each phase consists of two rectangular-section conductors mounted side by side and on edge.

In all the section, the busbars run in the same front section.

This makes it possible to be kept equidistant and well aligned.

The busbars have been supported with high quality insulating material, in the form of arc barriers, so that it prevents an arc from spreading out into the adjacent compartments.

Vertical and branch busbars

Power is fed to the withdrawable units through the isolating contacts of the HCB plug on to the branch busbars.

Module Compartments

Withdrawable units

Each withdrawable unit is housed in its own self contained compartment.

Each cubicle is separated by max. 24 withdrawable units.

The compartment consist of the isolating contacts for main and control circuits, together with the withdrawable unit from a "functional unit."



Module compartment of
M.C.C type H8PU-S7



Cable Compartments

Cable termination

Following standard versions are available.

Front only / Front cabling access type

A separate cable compartment door is provided on the right side of panels.

Back-to-back type

A separate cable compartment door is provided on each right side of panels.

Control supply

For control supply derived from a common transformer, facilities are provided for the accommodation of horizontal and vertical control supply busbars. Horizontal control supply bars are housed in a free space below the busbars chamber.

The control supply is fed to the individual withdrawable unit from vertical double pole control busbars.

They are fitted to the right-hand side of the vertical bar duct and are connected to contacts in the 32-pole control circuit isolating plug.



Door interlock

Whenever a HCB compartment door is to be secured against unauthorized switching off or careless HCB operation, a door interlock can be fitted.

Cable compartment of
M.C.C type H8PU-S7



Panel arrangement and dimensions

• Bottom cable entry (standard type)

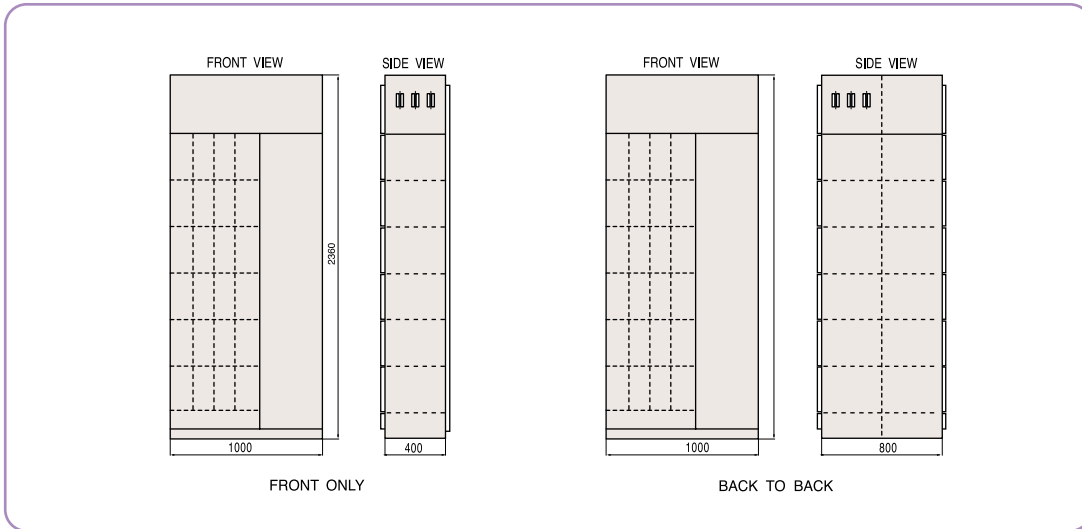

• Top cable entry (option)

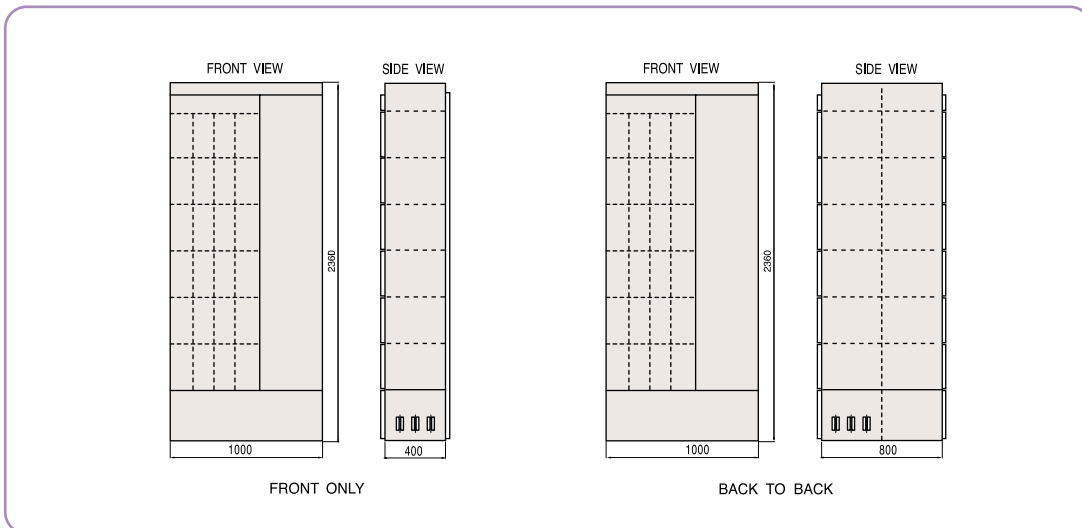

The height with bottom base frame is 2400mm (special type)

| Standing against a wide panel | Standing against a wall wide panel |
|---|---|
| Front mounting | Back-to-back mounting |
| Front cabling access | Front and rear cabling access |
| Separate cable compartment door at side | Separate cable compartment door at side |

■ ■ ■ *HCB Series*

Hyundai
Motor



HYUNDAI





MOTOR CONTROL BREAKER



Revolution of Motor Control Breaker Combination of Modern Technology

Hyundai Motor Control Breaker (HCB) has completely revolutionized the concept of motor starter. A new conceptual product, HCB is compact and sophisticated combination of modern technology.

Hyundai Motor Control Breaker(HCB)

In HCB, Moulded Case Circuit Breaker (MCCB), Electromagnetic Contactor (M.C.), Electrical Over-Current Relay (EOCR), ZCT, Protective Relay and Digital Ammeter are uniquely combined. HCB is excellent in reliability of high use-frequency, long life-time and high breaking performance. Especially, HCB users will benefit from reduction in space, cost and time.

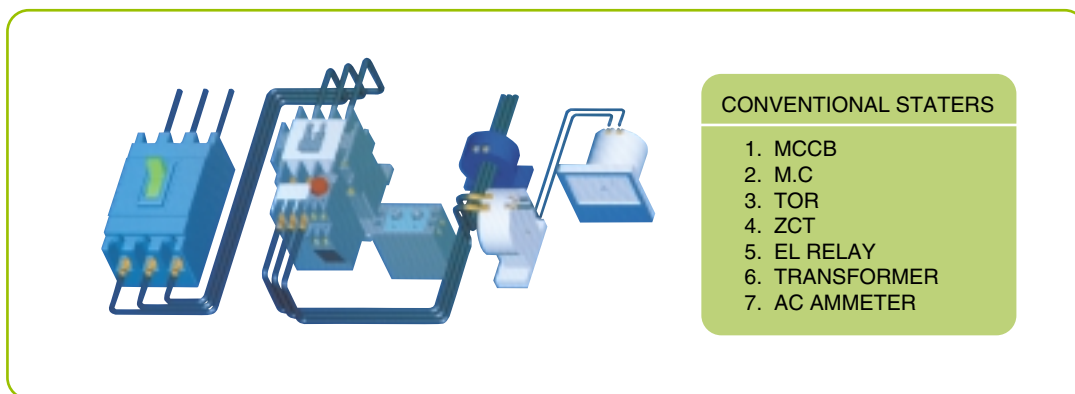



Characteristics
of HCB Series

Characteristics of HCB Series

High performance and high reliability

- Using an 8-bit CPU EMC & Environment Test Approval
- Mechanical endurance: 5 million
- Electrical endurance: 1 million

Multi-protective functions

8 types of protective functions are provided.
Users can select all functions except overload and short-circuit protection which are use or non-use.

- Overload protection (adjustable setting range)
- Short-circuit protection (adjustable setting range)
- Phase reverse protection
- Phase loss protection
- Phase unbalance protection
- Earth leakage protection (adjustable setting range) - Option
- Under-voltage protection (adjustable setting range)
- Over-voltage protection (adjustable setting range)

Overload pre-alarm function

LCD and LED (alarm contact) display overload conditions.

Multiple indication function (LCD display)

- Load current in phases. Phase unbalance rate
- Leakage current - Option Voltage (OCR control voltage)

Trip indication function (LCD display)

- Fault cause Trip current Tripping time

Remote control function

Being able to control motor using coil in the distance.

Auxiliary contacts

- Auxiliary contact: 4NO+4NC (Handle control type)
- Pre-alarm contact: 1NO
- Trip signal contact: 2C (Handle control type)

Hyundai Motor Control Breaker
Hyundai Motor Control Breaker
» **HCB Series**



Technical Data
Protective Characteristics

Technical Data

| Technical data | | | HCB64P |
|---|-------------|---------|--|
| Rated control voltage | COIL | V | 220V(85~265V), 440V(170~530V) |
| | OCR | | |
| Rated operational voltage | | V | 660 |
| Rated insulation voltage IEC 947 | | V | 660 |
| Rated thermal current I _{th} | | A | 64 |
| Rated motor output/ | 220V | | 15/64 |
| Rated operational current | 380V | KW/A | 30/62 |
| for AC3 duty | 440V | | 30/62 |
| | 660V | | 37/43 |
| Electrical endurance | | million | 1 |
| Mechanical endurance | | | 5 |
| Number of poles | | | 2, 3 |
| Adjustable range | Type of OCR | | Adjustable range |
| | 02 | | 0.5A~2A |
| | 06 | | 1.5A~6A |
| | 20 | | 5A~20A |
| 64 | | 16A~64A | |
| Rated breaking capacity (IEC 947-2) | 220VAC | KA | 85 |
| | 380VAC | KA | 50 |
| | 440VAC | KA | 42 |
| | 480VAC | KA | 42 |
| | 660VAC | KA | 10 |
| Multi-protective functions | | | |
| <ul style="list-style-type: none"> • Overload protection • Short-circuit protection • Phase reversal protection • Phase loss protection • Phase unbalance protection • Under-voltage protection • Over-voltage protection • Earth leakage protection - Option | | | <ul style="list-style-type: none"> - Inverse time delay (Adjustable : current, time) - Instantaneous (Adjustable : current) - Instantaneous - Definite time delay - Definite time delay - Definite time delay (Adjustable : Voltage) - Definite time delay (Adjustable : Voltage) - Definite time delay (Adjustable : current, time) |
| AC Ammeter | | | |
| Alarm | | | |
| DIN-Rail | | | x |
| Plug-IN | | | (all terminal) |

Protective Characteristics

| Function | Characteristics |
|-----------------|---|
| Overload | Non-trip at $[I_n] \times 1.05$, Trip at $[I_n] \times 1.20$ * setting tolerance : $\pm 10\%$ * Inverse time delay |
| Short-circuit | Trip at 100mSEC to the setting current and rate. * setting tolerance : ± 1 times |
| Phase unbalance | Trip at $30\% \pm 20\%$, 2SEC differences between max. and min phases. |
| Phase loss | Trip at $70\% \pm 10\%$, 2SEC differences between max. and min phases. |
| Negative phase | Trip at within 200mSEC. |
| Earth leakage | Trip at setting current and time. * setting tolerance : $\pm 10\%$ |
| Under-voltage | Trip at $70\% \pm 10\%$, 2SEC according to setting voltage. |
| Over-voltage | Trip at $120\% \pm 10\%$, 2SEC according to setting voltage. |

* Time tolerance : $\pm 20\%$ (Including the current tolerance)

Overload and short-current protection characteristics

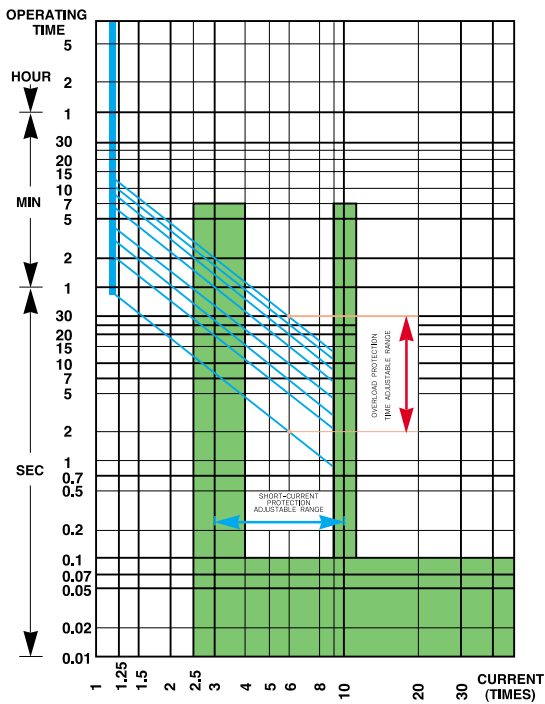

Earth leakage protection characteristics

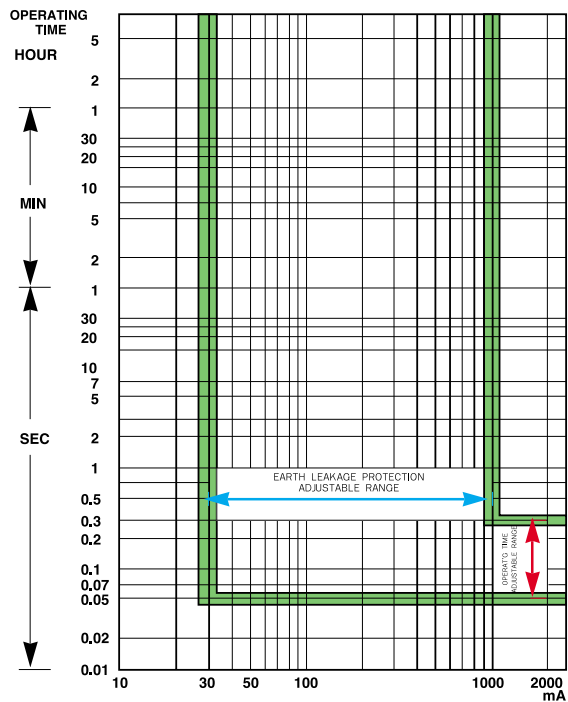

>> HCB Series



Setting Standards and Adjustable Ranges
LCD Display Contents
Order Form

Setting Standards and Adjustable Ranges

| Division | Display | Setting standards | Adjustable ranges | Adjustable steps |
|-----------------------------|---------------------------|--|---|--|
| Rated current | RATED CUR(A) | 02: 2A 06: 6A 20: 20A 64: 64A | 02: 0.5 ~ 2A 06: 1.5 ~ 6A 20: 5 ~ 20A 64: 16 ~ 64A | <ul style="list-style-type: none"> • 1A below: 0.05A • 5A below: 0.1A • 20A below: 0.5A • 20A above: 1A |
| Over-current operating time | TIME (SEC) | 2: 30 SEC 6: 30 SEC 20: 30 SEC 64: 10 SEC | 2: 2 ~ 30 SEC 6: 2 ~ 30 SEC 20: 2 ~ 30 SEC 64 { 50A: 2~20 SEC 50A: 2~10 SEC | <ul style="list-style-type: none"> • 02, 06, 20 type 2, 5, 7, 10, 15, 20, 25, 30 SEC • 64 type : 50A: 2, 5, 7, 10, 15, 20 SEC : 50A: 2, 5, 7, 10 |
| Short-current rates | SC (%) | 800 % | 300 ~ 1000 % | <ul style="list-style-type: none"> • 100 % |
| Earth leakage trip current | EL (A) | 1 A | 0.03 ~ 1 A | <ul style="list-style-type: none"> • 0.03, 0.1, 0.2, 0.3, 0.4, 0.6, 0.8, 1 A |
| Earth leakage trip time | EL-TIME (SEC) | 0.3 SEC | 0.5 ~ 0.3 SEC | <ul style="list-style-type: none"> • 0.5 SEC |
| Automatic reset time | AUTO (SEC/MIN) | non | non ¹⁾ , Pr ²⁾ 1SEC ~30MIN | <ul style="list-style-type: none"> • non • Pr • 60SEC below: 1SEC • 60SEC above: 1MIN |
| Under-voltage | UV (V) | 220: 85 V 440: 170 V | 220: 85 ~ 265 V 440: 170 ~ 530 V | <ul style="list-style-type: none"> • 150V below: 2 V • 100V below: 5 V • 100V above: 10 V |
| Over-voltage | OV (V) | 220: 265 V 440: 530 V | 220: 85 ~ 265 V 440: 170 ~ 530 V | <ul style="list-style-type: none"> • 150V below: 2 V • 100V below: 5 V • 100V above: 10 V |
| Function lock | PU, PL, NP, EL, UV, OV | non | USE/non | <ul style="list-style-type: none"> • USE: Using protective function • non: Locking protective function |

1) non: Manual resetting by the handle reset

2) Pr: Resetting by the control power OFF

References to the Under Voltage (UV) protective function

For the re-providing power after power interruption more than 1 SEC, HCB keep OFF or TRIP state regardless of the handle position to protect life and properties.

To re-start the HCB, please turn the handle OFF or RESET position and HCB must lie AUTO position.

LCD Display Contents

MODE

- MON1** Operating Data
- SET** Protection Setting
- TEST** Self-function Test

CURRENT/TIME & AUTO RESET DISPLAY

- **RATED CUR:** Rated Current
- **TIME:** Trip Time
- **AUTO:** Auto Reset

UNIT

- **A:** Current
- **SEC:** Second
- **MIN:** Minute
- **%:** Current, Voltage, Percent
- **V:** Voltage

DATA

- **R:** R-Phase Current
- **S:** S-Phase Current
- **T:** T-Phase Current
- **G:** Leakage Current
- **PU:** Phase Unbalance

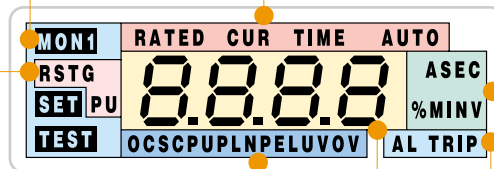

PRE-ALARM & TRIP

- **AL:** Overload Pre-alarm
- **TRIP:** Trip State

PROTECTION & FAULT DISPLAY

- **OC:** Over-Current
- **SC:** Short-Current
- **PU:** Phase Unbalance
- **PL:** Phase Loss
- **NP:** Negative Phase
- **EL:** Earth Leakage
- **UV:** Under-Voltage
- **OV:** Over-Voltage

DATA VALUES & FUNCTION SELECT

- **MEMBERS:** Current, Etc/Data, Values
- **USE:** Functions Usage
- **Non:** Functions Lock

Order Form

| | | | | | | | | |
|-------------------------------|--|---|---|-------------------------------|--|--|-----------------|--|
| HCB | 64P | W | 3 | S | A | 20 | 220 | X |
| Hyundai Motor Control Breaker | Frame Size 64P: Handle control type | AC/DC (control voltage) W: A.C G: D.C | Numbers of pole 2: 2 pole 3: 3 pole | Mounting method P: Plug-in | Additional functions A: Standard type B: Added earth leakage | OCR type (adjustable range) 02: 0.5 ~ 2A 06: 1.5 ~ 6A 20: 5 ~ 20A 64: 16 ~ 64A | Control voltage | Frequency of control voltage Blank: 60Hz X: 50Hz |

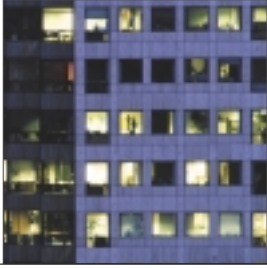

Setting Key Operation

| Use State | Mode Button | Set-Value Change Button | Set/Test Button |
|---|------------------------------------|---|---|
| AUTO/ OFF RESET state | MONI | R-phase current display | |
| | | S-phase current display | |
| | | T-phase current display | |
| | | Min/Max current difference rate display | |
| | | Leakage current (G) display | |
| | | L1, L2 power voltage display | |
| | SET | Rated current (RATED CUR.) setting | Determination of protective standard |
| | | Overload operating time(OC-TIME) setting | |
| | | Short-current (SC) rate setting | |
| | | Earth leakage (EL) current setting | |
| | | Earth leakage operating time(EL-TIME) setting | |
| | | Auto-reset time (AUTO-TIME) setting | |
| | | OCR under voltage (UV) setting | |
| | | OCR over voltage (OV) setting | |
| | Communication address (CN) setting | | |
| | SET | Phase-unbalance(PU)function use/non setting | USE/non determination |
| | | Phase loss(PL) function use/non setting | |
| | | Negative phase (NP) function use/non setting | |
| Earth leakage (EL) function use/non setting | | | |
| Under voltage (UV) function use/non setting | | | |
| Over voltage (OV) function use/non setting | | | |
| ISOL/ TEST state | TEST | Main and auxiliary contacts operating test | TEST execution/stop |
| | | Pre-alarm contacts operating test | |
| | | Trip contacts operating test | |
| TRIP state | | Trip causes and data display | Standard type RESET |
| | | Overload tripping time display | |



>> **HCB Series**



Setting Key Operation
Setting Method

Setting Method

| Setting Method | Examples of Setting and LCD Display |
|--|-------------------------------------|
| <p>By pressing 'MODE' button, 'MONI' state is changed to 'SET' state and 'RATED CUR' flickered at the same time.</p> | |
| <p>If users wish to change set-value of any other functions such as overload operating time, short-current rates, short-current time and earth leakage current, etc, first press the set-value change buttons. Then pressing set button, the value is set and 'RATED CUR' flickers. (example: 5 A)</p> | |
| <p>By pressing the set-value change buttons, users can set the target current values. (example: 10 A)</p> | |
| <p>After pressing the 'SET' button, this setting current value become rated current of the product. Concurrently, the setting value flickers.</p> | |
| <p>By pressing the 'MODE' button it returns to the 'MONI' state. This 'MONI' state is usual using state.</p> | |



Outline Dimensions and Connection Diagram
 Plug-in Mounting Base Structure and Outline

Outline Dimensions and Connection Diagram

Handle control type (HCB64P)

• Outline dimensions

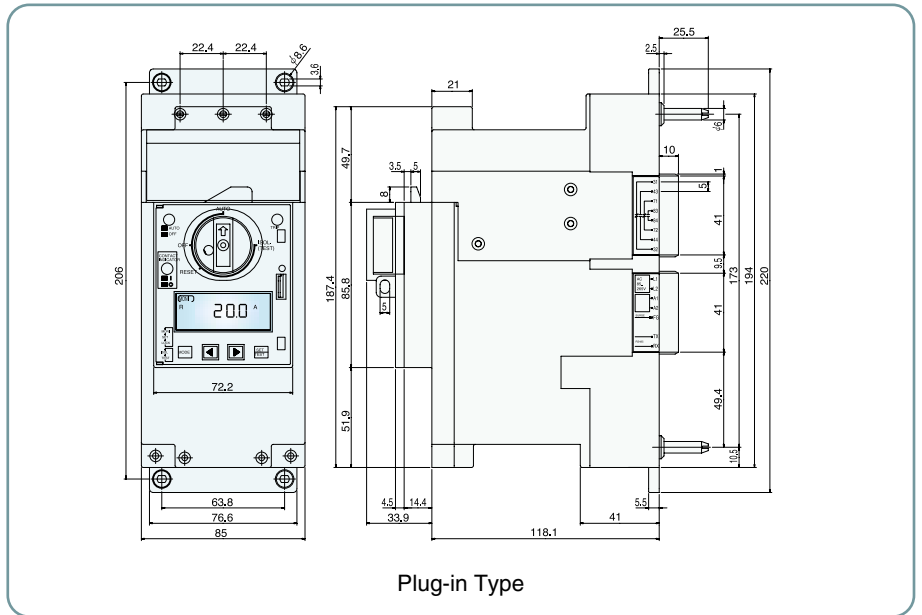

• Connection diagram

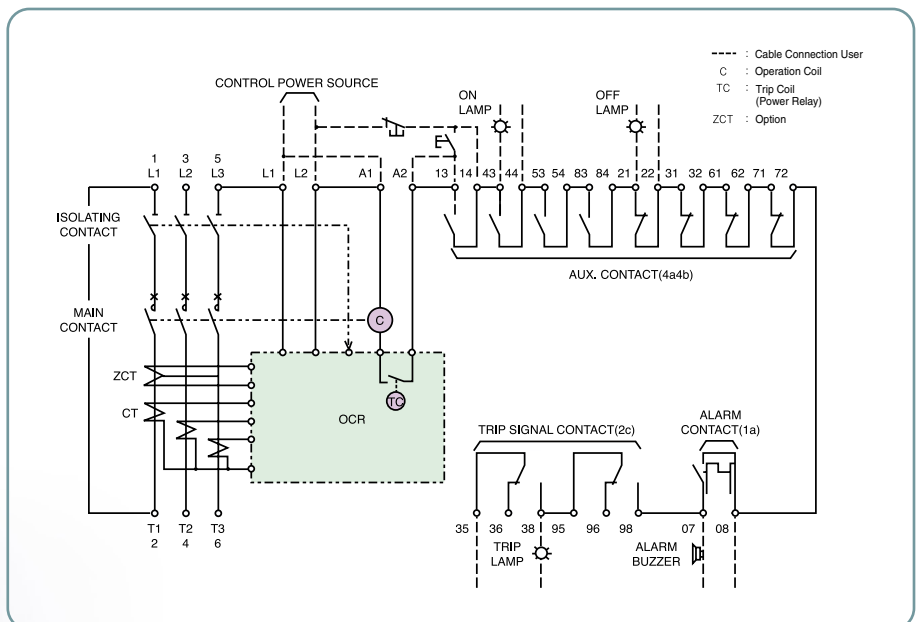



Plug-in Mounting Base Structure and Outline

Only handle control type (HCB64P)

• Structure

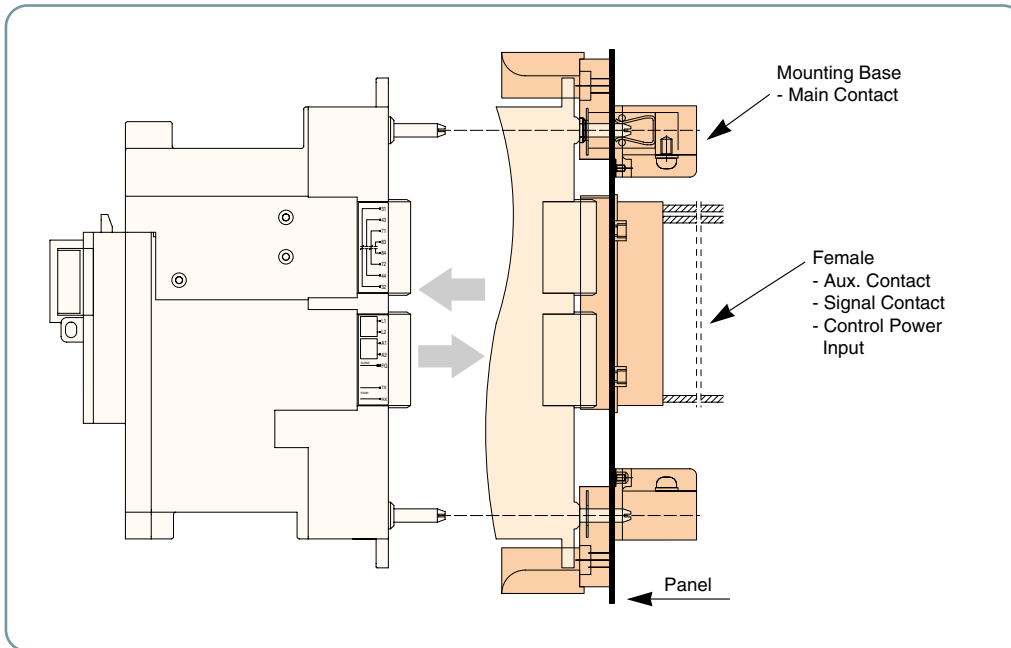

Order form
:HCBMB 64P

• Outline dimensions

